



2/2 way Proportional Valve (motor-driven)

- Actuator isolated from flow path
- Excellent range and fast response times
- Low power consumption
- Orifice sizes 8 to 25 mm
- Versions: Standard, positioner, process controller



Product variants described in the data sheet may differ from the product presentation and description.

Can be combined with

	Type 8006 Mass Flow Meter (MFM) ▶
	Type 8008 Flowmeter for gases ▶
	Type 8746 Mass flow controller (MFC) / Mass flow meter (MFM) for gases ▶
	Type 8611 eCONTROL - Universal controller ▶
	Type 8311 Pressure measuring device / Switch ▶

Type description

The direct-acting motor valve of type 3285 is used for dosing of liquids and gases in closed or open control loops. The valve features a stepper motor as the actuator. The integrated electronics simplifies the process integration; additional actuation modules are not necessary. The motor's power consumption to hold a specific opening position of the valve is zero. This key feature can reduce the energy consumption of a plant dramatically and thus make it more efficient. Type 3285 is available as a standard ON/OFF or proportional valve, as a version with integrated positioner and as a version with integrated process controller.

Table of contents

1. General Technical Data	3
1.1. General.....	3
1.2. Standard, positioner and process controller version.....	4
2. Materials	4
2.1. Chemical Resistance Chart – Bürkert resistApp.....	4
2.2. Material specifications.....	5
3. Dimensions	5
3.1. Threaded body.....	5
3.2. Capacitive buffer module.....	6
4. Device/Process connections	7
4.1. Analogue.....	7
4.2. Digital (Fieldbus).....	7
5. Performance specifications	8
5.1. Duty cycle derating diagram.....	8
5.2. Pressure range.....	9
5.3. Flow characteristic.....	9
Determination of the K_v value.....	9
6. Product operation	10
7. Product accessories	11
7.1. Accessories capacitive buffer module.....	11
7.2. Software Bürkert Communicator.....	11
Connection Type 3285 with Bürkert Communicator software.....	12
8. Ordering information	12
8.1. Bürkert eShop – Easy ordering and quick delivery.....	12
8.2. Recommendation regarding product selection.....	12
8.3. Bürkert product filter.....	12
8.4. Ordering chart accessories.....	12
General accessories.....	12
Accessories for positioner and process controller version.....	13

1. General Technical Data

1.1. General

Product properties	
Dimensions	Detailed information can be found in chapter "3. Dimensions" on page 5.
Material	
Fluid body	Brass or stainless steel
Valve body	PC (Polycarbonate), PPS (Polyphenylene sulfide)
Seal	NBR for liquids EPDM for liquids and special gases (e. g. ammonia, acetylene), FKM for neutral gases
Seat sealing	Technical ceramics
Weight	~ 800 g (DN 8) ... 1500 g (DN 25)
Status display	LED (Detailed information can be found in the instruction manual)
Performance data	
Nominal operating mode	Up to 100 % (depending on fluid and ambient temperature)
Typical values of positioning behaviour ^{1.)}	
Hysteresis	< 5 % of end value
Response sensitivity	< 1 % of end value
Setting range	1:100
Repeatability	< ± 2 %
Pressure range ^{2.)}	0...6 bar (see "5.2. Pressure range" on page 9)
Closing time	Ca. 4 s
Electrical data	
Operating voltage	24 V DC ± 10 % (max. residual ripple 10 %)
Power consumption	< 1 W in holding position Max. 12 W (depending on motor control)
Medium data	
Operating medium	Neutral gases, liquids
Medium temperature	0 °C...70 °C
Viscosity (max.)	80 mm ² /s (cSt)
Process/Port connection & communication	
Port connection size	G ½, G ¾, G 1, NPT ½, NPT ¾, NPT 1
Environment and installation	
Installation position	As required, preferably with actuator upright
Ambient temperature	- 10 °C...+60 °C
Degree of protection	IP50

1.) Characteristic data of control behaviour depends on process conditions.

2.) Pressure data [bar]: Overpressure with respect to atmospheric pressure

1.2. Standard, positioner and process controller version

Technical data	Device variant					
	Standard		Positioner		Process controller	
	ON/OFF	Control valve	Analogue	Digital (fieldbus)	Analogue	Digital (fieldbus)
Electrical connection	M12 Plug, A-coded, 8 pin	M12 Plug, A-coded, 8 pin	M12 Plug, A-coded, 8 pin	M12 Plug, A-coded, 5 pin	M12 Plug, A-coded, 8 pin and M12 Socket, A-coded, 5 pin	M12 Plug, A-coded, 5 pin and M12 Socket, A-coded, 5 pin
Input signal (setpoint)	Digital input: 0...5 V (log. 0, valve closed) or 10...30 V (log. 1, valve open)	4...20 mA, 0...10 V, or PWM (800 Hz)	4...20 mA, 0..20 mA, 0...10 V, or 0...5 V	–	4...20 mA, 0..20 mA, 0...10 V, or 0...5 V	–
Input signal (actual value from ext. Sensor)	–	–	–	–	4...20 mA, 0..20 mA, 0...10 V, 0...5 V	4...20 mA, 0..20 mA, 0...10 V, 0...5 V, or Frequency (5...2000 Hz)
Input impedance for analogue input	22 kΩ	60 Ω (current), 22 kΩ (voltage)	60 Ω (current), 22 kΩ (voltage)	–	60 Ω (current), 22 kΩ (voltage)	60 Ω (current), 22 kΩ (voltage)
Output signal (actual value)	Digital output: PNP, max. 100 mA current limits, feedback function (output signal active, when valve closed)	Digital output: PNP, max. 100 mA current limits, feedback function (output signal active, when valve closed)	0/4...20 mA (max. load: 560 Ω), 0...5/10 V (max. current: 10 mA)	–	0/4...20 mA (max. load: 560 Ω), 0...5/10 V (max. current: 10 mA)	–
Fieldbus interface	–	–	–	büS / CANopen	–	büS / CANopen
Parameterization Tool	–	–	Bürkert Communicator (Connection via büS stick)	Bürkert Communicator (Connection via büS stick)	Bürkert Communicator (Connection via büS stick)	Bürkert Communicator (Connection via büS stick)

2. Materials

2.1. Chemical Resistance Chart – Bürkert resistApp

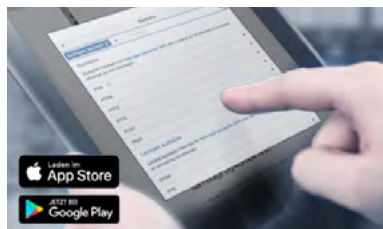

Bürkert resistApp – Chemical Resistance Chart

You want to ensure the reliability and durability of the materials in your individual application case? Verify your combination of media and materials on our website or in our resistApp.

[Start Chemical Resistance Check](#)

DTS 1000256911 EN Version: P Status: RL (released | freigegeben | valide) printed: 08.10.2020

2.2. Material specifications

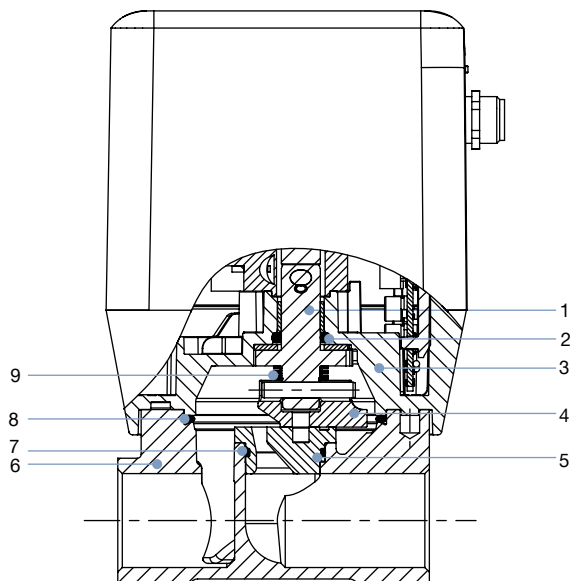

Nr.	Element	Material
1	Spindle seat	Stainless steel
2	Spindle	FKM/EPDM/NBR
3	Upper fluids housing	PPS Polyphenylene sulfide
4	Control disc	Technical ceramics
5	Fixed seat disc	Technical ceramics
6	Fluidic body	Brass or Stainless steel
7	O-Ring	FKM/EPDM/NBR
8	O-Ring	FKM/EPDM/NBR
9	Spring	Stainless steel

3. Dimensions

3.1. Threaded body

Note:
Dimensions in mm

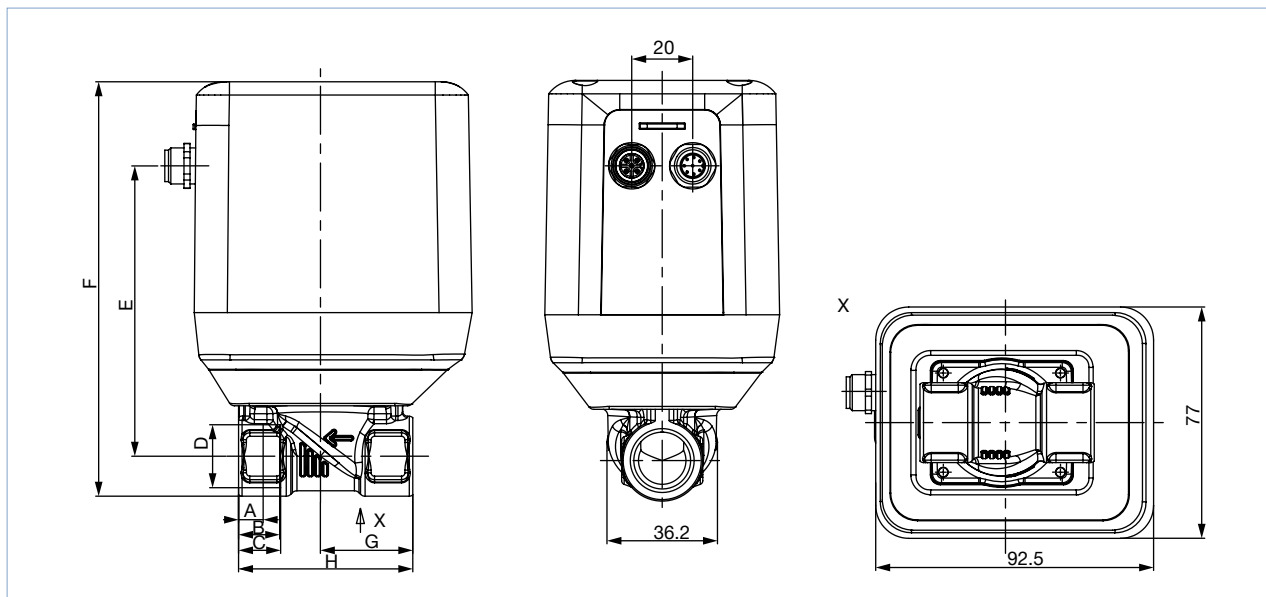

A	B	C	D	E	F	G	H	H
8.2	13.7	-	NPT 1/2	97	138	31	58	26.6
-	-	14	G 1/2	97	138	31	58	26.6
8.6	14	-	NPT 3/4	103.5	147	43	80	32
-	-	16	G 3/4	103.5	147	43	80	32
10.2	16.8	-	NPT 1	108.5	156.5	49	95	41
-	-	18	G 1	108.5	156.5	49	95	41

DTS 1000256911 EN Version: P Status: RL (released | freigegeben | valide) printed: 08.10.2020

3.2. Capacitive buffer module

Note:

- Dimensions in mm
- Detailed information can be found in chapter “7.1. Accessories capacitive buffer module” on page 11.

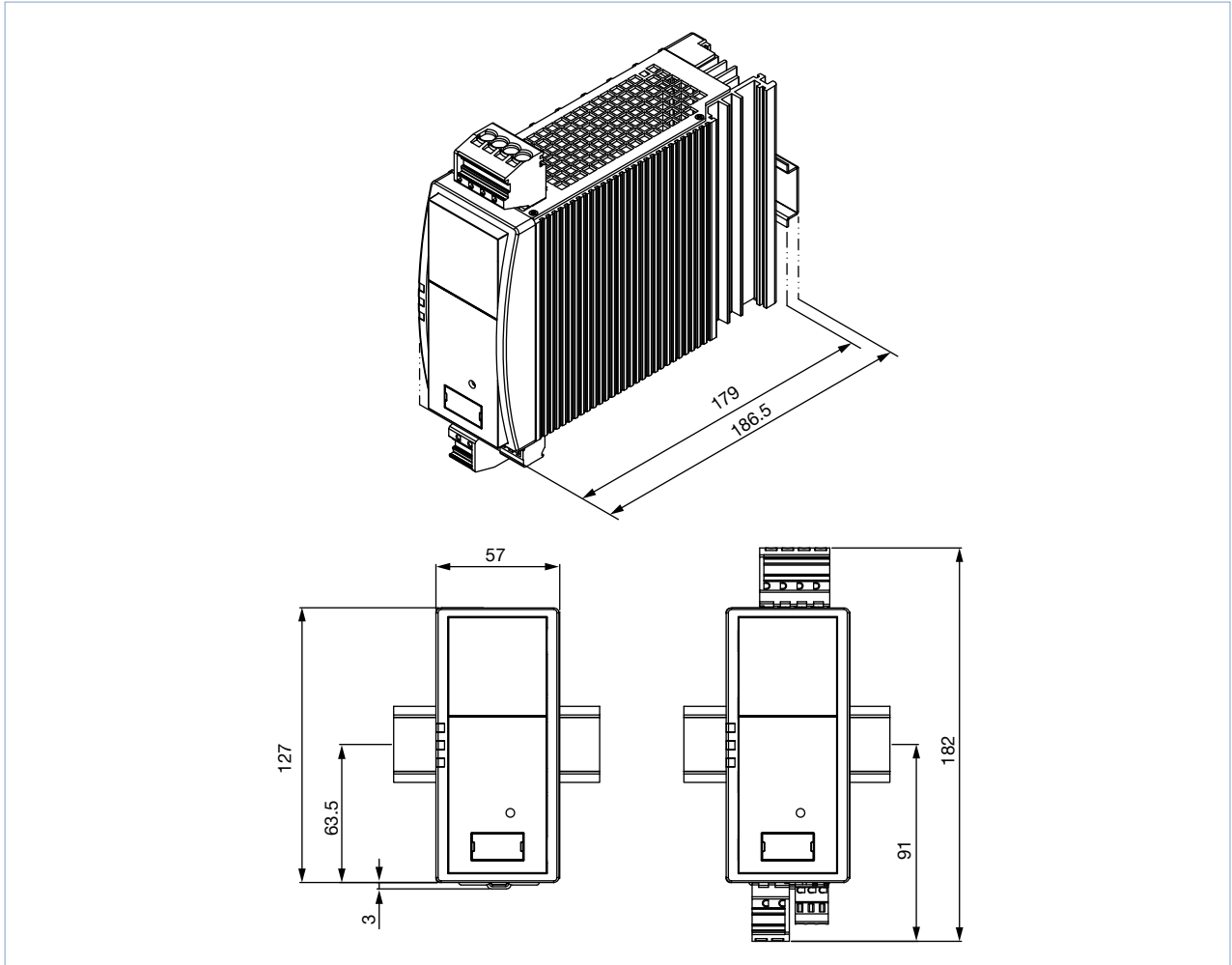

4. Device/Process connections

4.1. Analogue

Note:

For parameterisation and configuration of the positioner and the process controller versions, please use the Bürkert Communicator software tool, [“7.2. Software Bürkert Communicator” on page 11.](#)

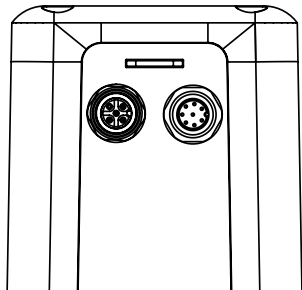

Circular connector M12, 8 pin	Pin	Configuration
	1	24 V DC
	2	Power supply GND
	3	Internal use ¹⁾
	4	Internal use ¹⁾
	5	Internal use ¹⁾
	6	Signal input +
	7	Signal output
	8	Signal GND

Only for positioners and process controllers version, for connection of the parameterization tools: Bürkert Communicator. The connection is via the büS-Stick. Using an adapter cable (M12 8 pin to M12 5 pin) the büS-Stick can be connected, see [“7.2. Software Bürkert Communicator” on page 11\).](#)

Additional for process controller version:

Socket M12, 5 pin	Pin	Configuration
	1	24 V DC sensor power supply
	2	Analogue IN (0...20 mA, 4...20 mA, 0...5 V or 0...10 V)
	3	GND
	4	GND (Bridge acc. to GND Pin3)
	5	Not connected

4.2. Digital (Fieldbus)

Note:

For parameterisation and configuration of the positioner and the process controller versions, please use the Bürkert Communicator software tool, [“7.2. Software Bürkert Communicator” on page 11.](#)

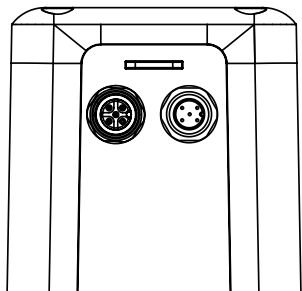

Circular connector M12, 5 pin	Pin	Configuration
	1	Shield
	2	24 V DC
	3	GND
	4	CAN high
	5	CAN low

Additional for process controller version:

Socket M12, 5 pin	Pin	Configuration
	1	24 V DC sensor power supply
	2	Analogue IN (0...20 mA, 4...20 mA, 0...5 V or 0...10 V)
	3	GND
	4	GND (Bridge acc. to GND Pin3)
	5	Not connected

5. Performance specifications

5.1. Duty cycle derating diagram

Note:

- For motor valves it is essential to know the duty cycle during operation. Self-heating of the motor limits the maximum duty cycle. High ambient temperatures amplify the risk of damage due to overheating. The diagram below shows the suggested duty cycles dependent on the ambient temperature. Running the motor control valve in the power saving mode (lower actuator force) allows higher duty cycles. The motor is optimized for the valve function regarding dimensions, power consumption and costs.
- The duty cycle does not refer to the duty cycle of the device but to the duty cycle of the motor. This is not switched on unless the valve is to move. Frequent set-point value changes will drastically increase the duty cycle of the motor.
- Operating the valve beyond the suggested duty cycles leads to a drastically reduced lifetime of the valve.

Derating curve for standard version

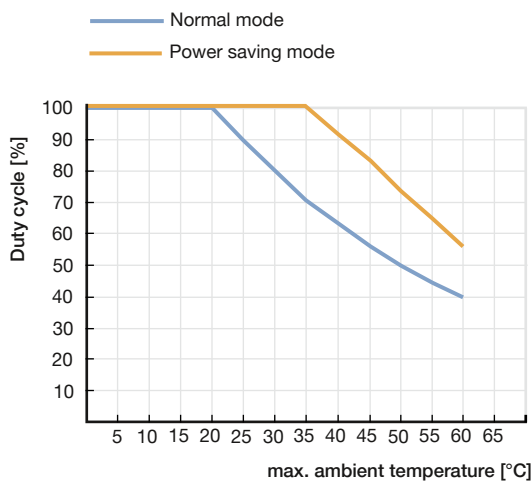

Derating curve for positioner and process controller

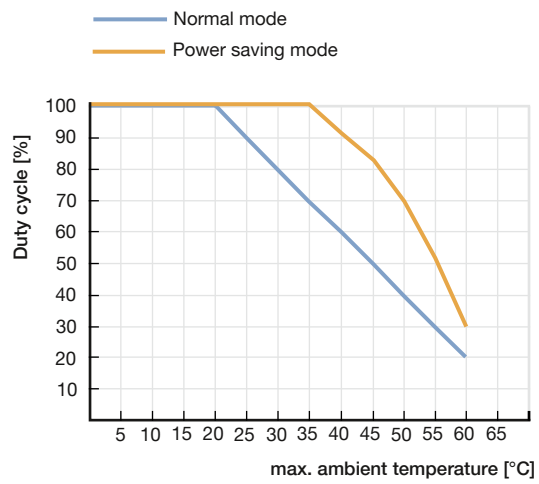

5.2. Pressure range

Note:

Please use the product filter of our [eShop](#) on the Bürkert website to order from the standard program. Alternatively, the form can be used at the end of the data sheet.

Valve function	Nominal diameter/ Orifice	Port connection ^{1.)}	K _{vs} -value water	Pressure range ^{3.)}
	[mm]		[m ³ /h] ^{2.)}	[bar(g)]
Control valve, without safety position in case of power failure	8	G ½	1.8	6
	10	G ½	2.5	6
	12	G ¾	3.9	6
	15	G ¾	5.4	6
	20	G 1	8.1	6
	25	G 1	9.6	6

1.) Other cable connections (NPT, sub-base) on request

2.) K_{vs}-value: Measured with water (20 °C) and 1 bar pressure drop over valve

3.) Fuel gases may vary

Further versions on request



Analytical

Oxygen version

Parts oil-, fat- and silicon free

5.3. Flow characteristic

Determination of the K_v value

Note:

Once the K_v-value required for the application has been calculated, it can be compared with the K_{vs}-values from the ordering chart. The K_{vs}-value must be higher than the K_v-value of the application, but should be neither too high nor too close to it - as a recommendation: 10 % higher.

Pressure drop	K _v value for liquids	K _v value for gases
	[m ³ /h]	[m ³ /h]
Sub-critical $p_2 > \frac{p_1}{2}$	$= Q \sqrt{\frac{\rho}{1000 \Delta p}}$	$= \frac{Q_N}{514} \sqrt{\frac{T_1 \rho_N}{p_2 \Delta p}}$
Supercritical $p_2 < \frac{p_1}{2}$	$= Q \sqrt{\frac{\rho}{1000 \Delta p}}$	$= \frac{Q_N}{257 p_1} \sqrt{T_1 \rho_N}$

K _v Flow coefficient	[m ³ /h] ^{1.)}
Q _N Standard flow rate	[m _N ³ /h] ^{2.)}
p ₁ Inlet pressure	[bar] ^{3.)}
p ₂ Outlet pressure	[bar] ^{3.)}
Δp Differential pressure p ₁ ...p ₂	[bar]
ρ Density	[kg/m ³]
ρ _N Standard density	[kg/m ³]
T ₁ Medium temperature	[(273+t)K]

1.) Measured for water, Δp = 1 bar, over the valve

2.) At reference conditions 1.013 bar and 0 °C (273 K)

3.) Absolute pressure

6. Product operation

Standard on/off valve

In the ON / OFF version, an external voltage signal is digitized and the valve is closed or opened. The status of the two end positions of the valve are indicated on the LED. In addition, the valve position “closed” is reached via the digital output.

Standard control valve

The standard proportional valve converts an external standard signal (position set-point value) into a valve position. Both valve end positions are indicated by the LED status. Additionally, the digital output indicates when the “closed” valve position has been achieved.

Process diagram	Description
	<p>Positioner version</p> <p>The positioner proportional valve converts an external standard signal (position set-point value) into a valve position. The position of the actuator is controlled according to the position set-point value. The current position (POS) of the electromotive valve is recorded by the position measuring system. The position controller compares this position actual value to the set-point value (CMD) specified as the standard signal. In case of a control difference (Xd1), the motor control signal is sent to the actuating drive as the actuating variable. Z1 is a disturbance value.</p> <p>Both valve end positions are indicated by the LED status. Moreover, the position actual value recorded using the position measuring system is output via the M12 circular plug-in connector.</p>
	<p>Process controller version</p> <p>The additionally implemented PID controller can perform not only the actual position control but also a process control in the sense of a cascade control. The process controller is integrated in a control circuit. The position set-point value of the valve is calculated from the process set-point value and the process actual value using the control parameters (PID controller). The process set-point value can be specified by an external signal. During the process control the position control mentioned above becomes the subordinate auxiliary control circuit; this results in a cascade control. The process controller in the main control circuit has a PID function.</p> <p>The process set-point value (SP) is specified as a set-point value and is compared with the actual value (PV) of the process variable to be controlled. The position measuring system records the current position (POS) of the electromotive linear actuator. This position actual value is compared by the position controller with the set-point value (CMD) specified by the process controller. If there is a control difference (Xd2), the actual position (POS) and therefore the valve opening are changed by the control variable (CTRL). Z2 represents a disturbance variable.</p>

DTS 1000256911 EN Version: P Status: RL (released | freigegeben | validé) printed: 08.10.2020

7. Product accessories

7.1. Accessories capacitive buffer module

Note:

- Dimensions see “3.2. Capacitive buffer module” on page 6.
- Ordering information see “8.4. Ordering chart accessories” on page 12.

Accessories	Description
<p>Motor valve(s) connection</p>  <p>24 V DC power supply For example: Single phase, primary switched mode power supply Type 1573</p>	<ul style="list-style-type: none"> • Capacitive buffer module for moving to a safety position in case of power failure • In order to be able to move to a safety position of the valve in the event of a power failure, the valve must be supplied with voltage via the capacitive buffer module. In the event of a power failure, the buffer module provides an output voltage of 18 V DC for a few seconds. The reduced input voltage is detected by the valve and the safety position is approached accordingly. Up to 3 valves of Type 3280 or 2 valves of Type 3285 can be connected to a buffer module. Factory setting of the safety position: “valve closed” • For standard version (functionality available as of software version A.08): adjustable via DIP switches (for the reverse operating direction, the safety position changes to “valve open”. • For positioner and process controller version (functionality available as of software version A.06): adjustable via Bürkert Communicator (user-defined safety position)

7.2. Software Bürkert Communicator

Note:

To install the software, click [here](#).

An adjustment of the valve by the Bürkert Communicator is only possible with the positioner or process controller versions.

Part of Bürkert’s new EDIP program (Efficient Device Integration Platform) is the Bürkert Communicator. This software can be run under MS-Windows and it is available on Bürkert’s website for free. The Bürkert Communicator allows convenient system configuration and parametrisation of all connected field devices. An accessory part, the bÜS stick serves as the interface between computer and process instruments (see “8.4. Ordering chart accessories” on page 12) The Communicator allows:

- Diagnostics
- Parameterisation
- Registration and storage of process data
- To watch graph of process
- To update firmware of the device connected
- Parameterisation of the integral positioner and (if available) process controller

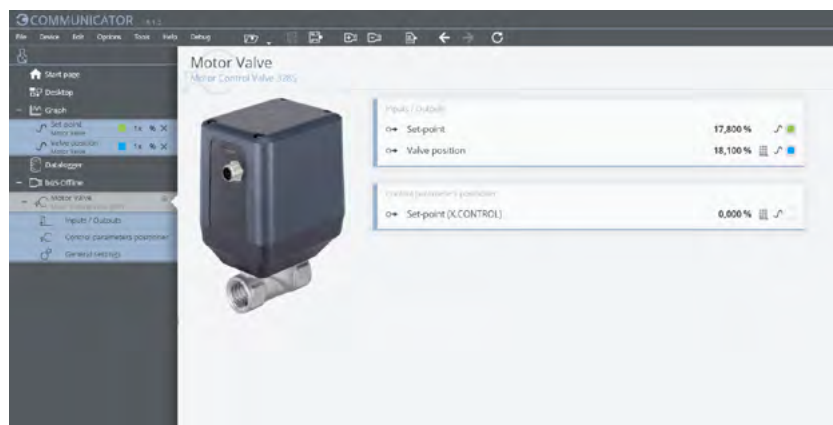

DTS 1000256911 EN Version: P Status: RL (released | freigegeben | validé) printed: 08.10.2020

Connection Type 3285 with Bürkert Communicator software

The interface to the “Bürkert Communicator” software tool is based on CANopen. A corresponding bus termination is mandatory. For versions with standard signal interfaces, please activate the switchable terminating resistor on the büS stick. For versions with büS / CANopen communication interface, this terminating resistor should not be switched on if the device is already integrated in a properly terminated bus network.

- A büS stick is required to connect the motor valve to the “Bürkert Communicator” software tool. The büS stick sets contain the necessary accessories.
- Versions with büS / CANopen communication interface are connected directly via the 5 pin M12 plug (büS stick set 1 contains the necessary accessories).
- Versions with standard signal interfaces are connected via the 8 pin M12 plug on the device (büS stick set 1 + büS adapter; socket 8 pin-M12 to plug 5 pin-M12 contain the necessary accessories).

8. Ordering information

8.1. Bürkert eShop – Easy ordering and quick delivery



Bürkert eShop – Easy ordering and fast delivery

You want to find your desired Bürkert product or spare part quickly and order directly? Our online shop is available for you 24/7. Sign up and enjoy all the benefits.

[Order online now](#)

8.2. Recommendation regarding product selection

Note:

- The configuration of the nominal diameter/orifice is very important for proportional valves to ensure proper functioning within the application. The nominal diameter/orifice must be selected in such a way that on the one hand the desired flow range is achieved and on the other hand a sufficient part of the total pressure drop across the valve takes place when the valve is fully open.
- Reference value: pressure drop of the valve > 25 % of the total pressure drop
- Let Bürkert engineers advise you already in the planning phase!

8.3. Bürkert product filter



Bürkert product filter – Get quickly to the right product





You want to select products comfortably based on your technical requirements? Use the Bürkert product filter and find suitable articles for your application quickly and easily.

[Try out our product filter](#)





8.4. Ordering chart accessories

General accessories

Description	Article no.
M12 socket, 8 pin with 2 m ready to use cable	919061
M12 socket, 8 pin with 2 m ready to use cable shielded cable	918991
Power supply Type 1573 for rail mounting, 100–240 V AC/ 24 V DC, 1.25 A, NEC Class 2 (UL 1310)	772438

Description	Article no.
Power supply Type 1573 for rail mounting, 100–240 V AC/ 24 V DC, 1 A	772361 
Power supply Type 1573 for rail mounting, 100–240 V AC/ 24 V DC, 2 A	772362 
Power supply Type 1573 for rail mounting, 100–240 V AC/ 24 V DC, 4 A	772363 
Buffer module Type 1573 for safety position when power failure	773440 

Accessories for positioner and process controller version

Description	Article no.
M12 plug, 5 pin with 2 m ready to use cable shielded cable	559177 
büS adapter, M12 socket, 8 pin to M12 plug, 5 pin (for büS stick connection)	773286 
büS-Stick Set 1 (incl. power supply, büS-Stick, termination resistor, Y-connector, cable, ...)	772426 
büS-Stick Set 2 (incl. büS-Stick, termination resistor, Y-connector, cable)	772551 
Software Bürkert Communicator	Download from www.burkert.com

Bürkert – Close to You

For up-to-date addresses
please visit us at
www.burkert.com

DTS 1000256911 EN Version: P Status: RL (released | freigegeben | validé) printed: 08.10.2020



Product Enquiry Form - Proportional valve

Thank you for your interest in our products! In order to provide you with optimum advice, please fill out the following form and send it to your **Bürkert representative** or e-mail address: info@burkert.com. All information submitted will of course be kept strictly confidential.

Please fill in the **required fields!** *

*Note: The interactive functions of this PDF may be restricted depending on the PDF reader used.

Personal Information			
Company		Contact person	
Customer no.		Department	
Street		Postcode / Town	
Telephone no.		Email	

Delivery	
Quantity	Required delivery date

Operating data			
Function <small>(Function of the control valve in the process / process description)</small>			
Operating medium			
Type of medium	Fluid	Steam	Gas
Supply voltage	V		
Ambient temperature (max.)	$t_{u,max} =$	°C / °F	

Fluidic data			
Flow range Q_{Nom}	min.	max.	unit
Inlet pressure at Q_{Nom}	$p_1 =$	barg ^{1.)}	
Outlet pressure at Q_{Nom}	$p_2 =$	barg ^{1.)}	
Max. inlet pressure	$p_{1,max} =$	barg ^{1.)}	
Medium temperature (min./max.)	$t_{m,min} =$	$t_{m,max} =$	°C / °F
Port connection	G (DIN ISO 228/1) Flange	NPT (ANSI B1.2) Other	

1.) Please indicate all pressure values as overpressure to atmospheric pressure [barg] (g = relative pressure)

Material specifications			
Body	Stainless steel	Brass	Other
Seals	FKM	EPDM	Other

Approvals / Conformities
e. g. UL/UR, KTW W270, DVGW Gas, ATEX/IECEX, EAC, etc.

Additional Requirements / Comment

DTS 1000256911 EN Version: P Status: RL (released | freigegeben | valide) printed: 08.10.2020